

OPERATIONS MANAGEMENT

MANAGEMENT, OPERATIONS, AND MARKETING DEPARTMENT PROGRAM EVALUATION AND PLANNING SHEET

CATALOG YEAR 2011-2012

- NOTE: a) This form is a companion to the CSUS Admission Status & General Education Evaluation Form provided by the Office of Enrollment Services - not a replacement for it. All decisions regarding admission status and General Education evaluation are made by Enrollment Services.
- b) Be sure you have successfully completed all course prerequisites before enrolling in a course or you will not be allowed to register or stay in the course.
- c) ALL COURSES MUST BE COMPLETED WITH A GRADE OF "C-" OR BETTER.

PREREQUISITES TO THE MAJOR

Course	Title	Term	Grade	Course	Title	Term	Grade
ACC 2110	Financial Accounting			ECON 2510	Principles of Microeconomics		
ACC 2130	Managerial Accounting			MATH 1500	Finite Mathematics		
BLW 2060	Law, Environment, and Ethics			MATH 1610	Statistics for Decision Making		
BUS 2090	Ethics & Social Resp. for Business			BUS 3100	Business and Technical Writ OR		
ECON 2500	Principles of Macroeconomics			ENGL 3007	Business Technical Comm		

BUSINESS ADMINISTRATION CORE

Course	Title	Term	Grade	Course	Title	Term	Grade
MGT 3310	Management Theory & Practice			MKT 3410	Principles of Marketing		
FIN 3220	Business Finance			OM 3010	Operations Management		
MGT 3400	International Business			OM 3020	Management Science		
CIS 3700	Information Tech. for Mgt			* MGT 4900	Business Policy		

OPERATIONS MANAGEMENT CONCENTRATION REQUIREMENTS (12 units)

Course	Title	Term	Grade	Course	Title	Term	Grade
OM 4530	Materials & Inventory Mgt			OM 4580	Supply Chain Mgt		
OM 4570	Quality & Prod. Mgt			OM 4600	Lean Operations Strategy		

PLUS 1 of the following as approved by the Advisor (3-4 units)

Course	Title	Term	Grade	Course	Title	Term	Grade
CIS 4570	Decision Support Systems			MKT 4450	Channel Inst. & Retail Mgt		
COMM 3110	Organizational Comm			OM 4560	Management of Tech		
MGT 4340	Executive Leadership			OM 4590	Global Op Strategies		
MGT 4620	Sem in Labor Mgt Relation			OM 4890	Business Forecasting & Plan		

Getting Started: Before seeing your advisor, you should view the Catalog and Class Schedule online at www.csustan.edu. The list of advisors is posted on the door of DBH 223 or you can go to the Student Success Center in DBH 217/222. The catalog contains descriptions of all courses including prerequisites, core courses, and concentration courses. Lower division courses (numbered in the 1000s and 2000s) generally have acceptable equivalents transferable from a junior college. The junior college or the CSUS Academic Resource Center in MSR 180 should be able to advise you on this. Upper division courses (3000s and 4000s) must be taken at CSUS or another four-year institution.

PREREQUISITES AND CORE REQUIREMENTS

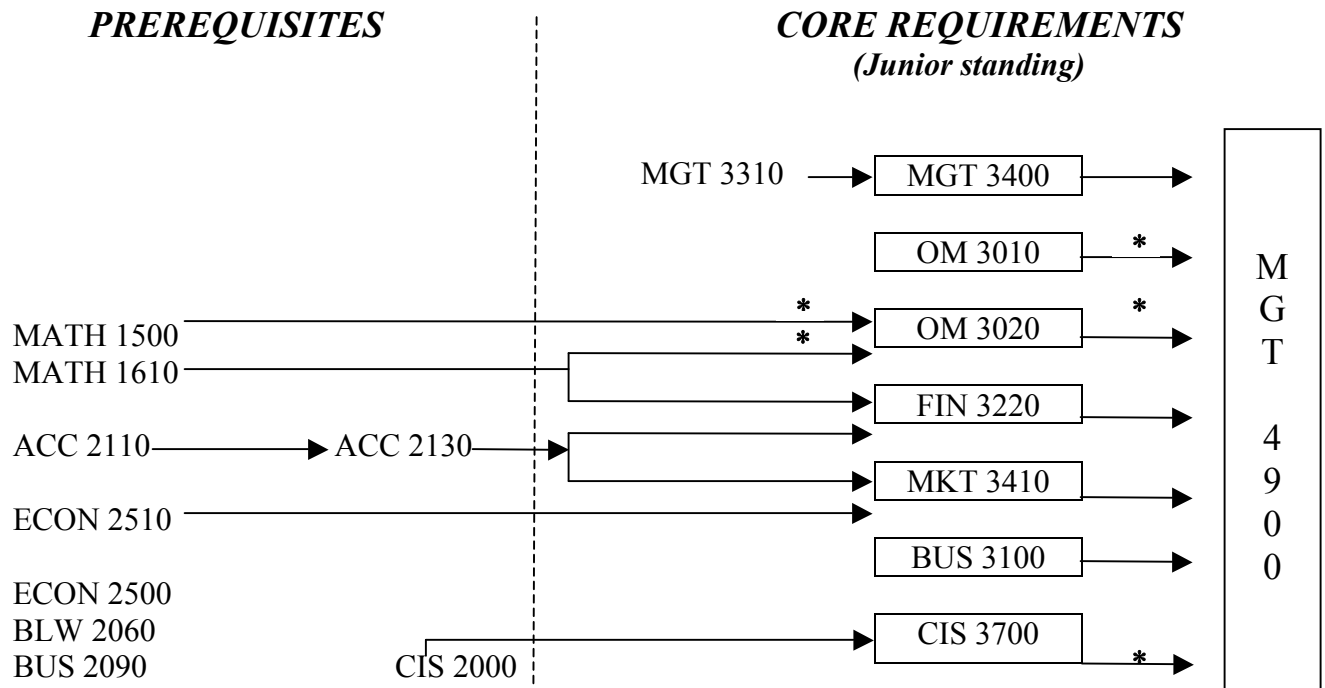

OPERATIONS MANAGEMENT CONCENTRATION REQUIREMENTS

