

MANAGEMENT CONCENTRATION

Strategy/Entrepreneurship Track

MANAGEMENT, OPERATIONS, AND MARKETING DEPARTMENT PROGRAM EVALUATION AND PLANNING SHEET

CATALOG YEAR 2011-2012

- NOTE: a) This form is a companion to the CSUS Admission Status & General Education Evaluation Form provided by the Office of Enrollment Services - not a replacement for it. All decisions regarding admission status and General Education evaluation are made by Enrollment Services.
- b) Be sure you have successfully completed all course prerequisites before enrolling in a course or you will not be allowed to register or stay in the course.
- c) ALL COURSES MUST BE COMPLETED WITH A GRADE OF "C-" OR BETTER.

PREREQUISITES TO THE MAJOR

Course	Title	Term	Grade
ACC 2110	Financial Accounting		
ACC 2130	Managerial Accounting		
BLW 2060	Law, Environment, and Ethics		
BUS 2090	Ethics & Social Resp. for Business		
ECON 2500	Principles of Macroeconomics		

Course	Title	Term	Grade
ECON 2510	Principles of Microeconomics		
MATH 1500	Finite Mathematics		
MATH 1610	Statistics for Decision Making		
BUS 3100	Business and Technical Writ OR		
ENGL 3007	Business Technical Comm		

BUSINESS ADMINISTRATION CORE

Course	Title	Term	Grade
MGT 3310	Management Theory & Practice		
FIN 3220	Business Finance		
MGT 3400	International Business		
CIS 3700	Information Tech. for Mgt		

Course	Title	Term	Grade
MKT 3410	Principles of Marketing		
OM 3010	Operations Management		
OM 3020	Management Science		
* MGT 4900	Business Policy		

* ALL prerequisite and business core courses must be taken before enrolling in MGT 4900, Business Policy.

EMPHASIS IN STRATEGY/ENTREPRENEURSHIP TRACK

Course	Title	Term	Grade
MGT 4920	Global Competitive Strategy		

Course	Title	Term	Grade
MGT 4540	Entrp. & Venture Initiative		

PLUS 2 of the following courses

Course	Title	Term	Grade
MGT 4000	Organization & Environment		
MGT 4340	Executive Leadership		

Course	Title	Term	Grade
MGT 4560	Seminar Small Business Mgt		
MGT 4950	Selected Topics in Mgt		

PLUS 1 of the following courses (as approved by advisor)

Course	Title	Term	Grade
COMM 4210	Public Relations		
ECON 4331	Managerial Economics		
ECON 4455	U.S. and World Trade		
FIN 4820	Seminar in Financial Mgt		
MKT 4490	Strategic Marketing Mgt		

Course	Title	Term	Grade
OM 4570	Quality Management		
PSCI 4315	Public Policy Making		
PSCI 4350	Govt, Business & Economy		
SOCL 4800	Formal Org in Modern Soc		

Getting Started: Before seeing your advisor, you should view the Catalog and Class Schedule online at www.csustan.edu. The list of advisors is posted on the door of DBH 223 or you can go to the Student Success Center in DBH 217/222. The catalog contains descriptions of all courses including prerequisites, core courses, and concentration courses. Lower division courses (numbered in the 1000s and 2000s) generally have acceptable equivalents transferable from a junior college. The junior college or the CSUS Academic Resource Center in MSR 180 should be able to advise you on this. Upper division courses (3000s and 4000s) must be taken at CSUS or another four-year institution.

COLLEGE OF BUSINESS ADMINISTRATION

PREREQUISITES AND CORE REQUIREMENTS

PREREQUISITES

CORE REQUIREMENTS
(Junior standing)

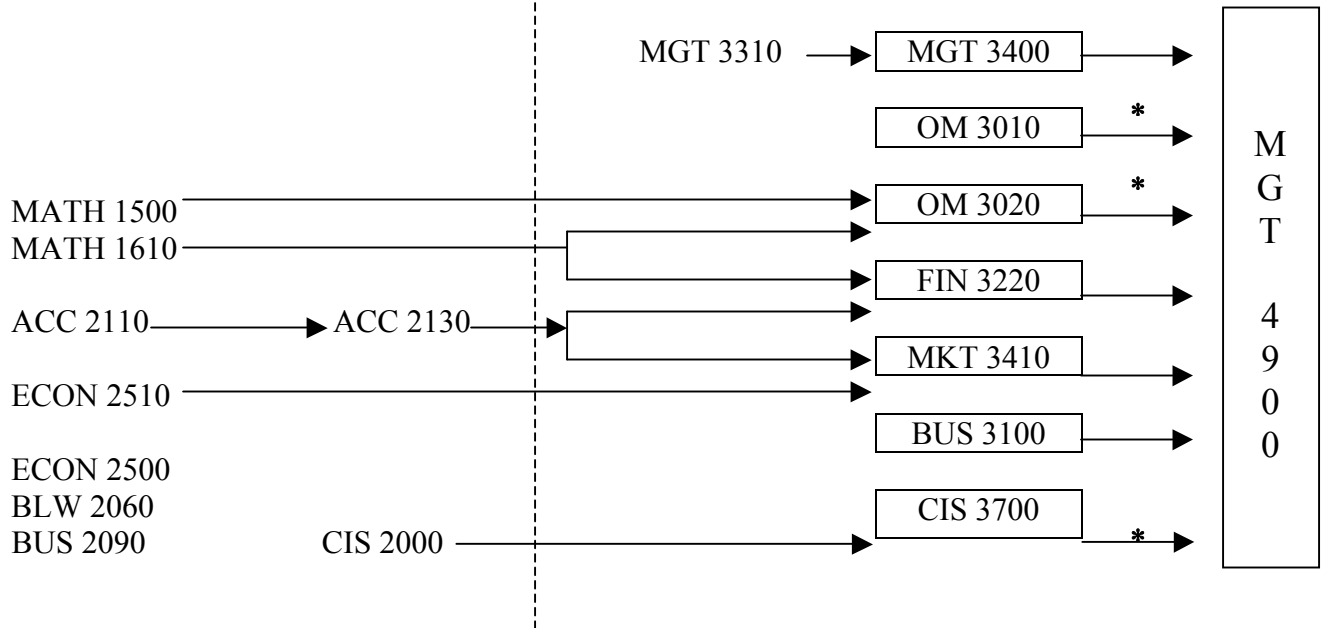

STRATEGY/ENTREPRENEURSHIP COURSE REQUIREMENTS

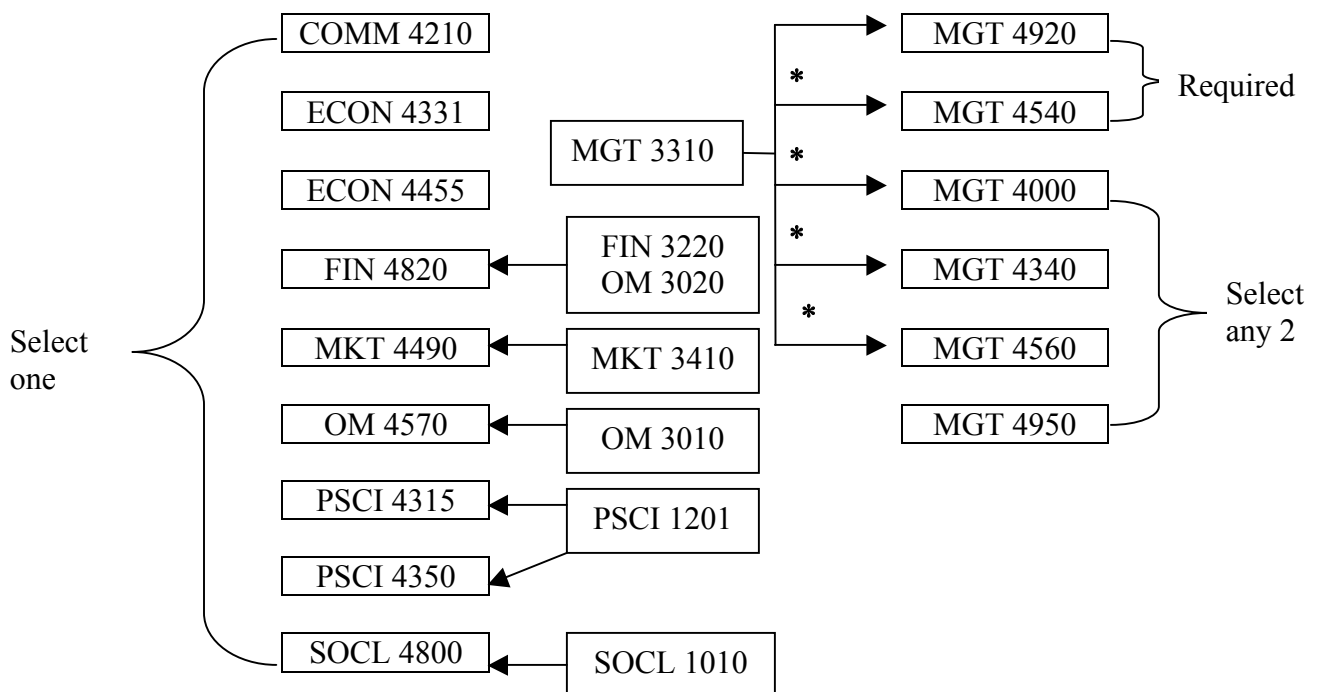

*** may be taken concurrent-**