

CORE PREREQUISITES

(From left to right)

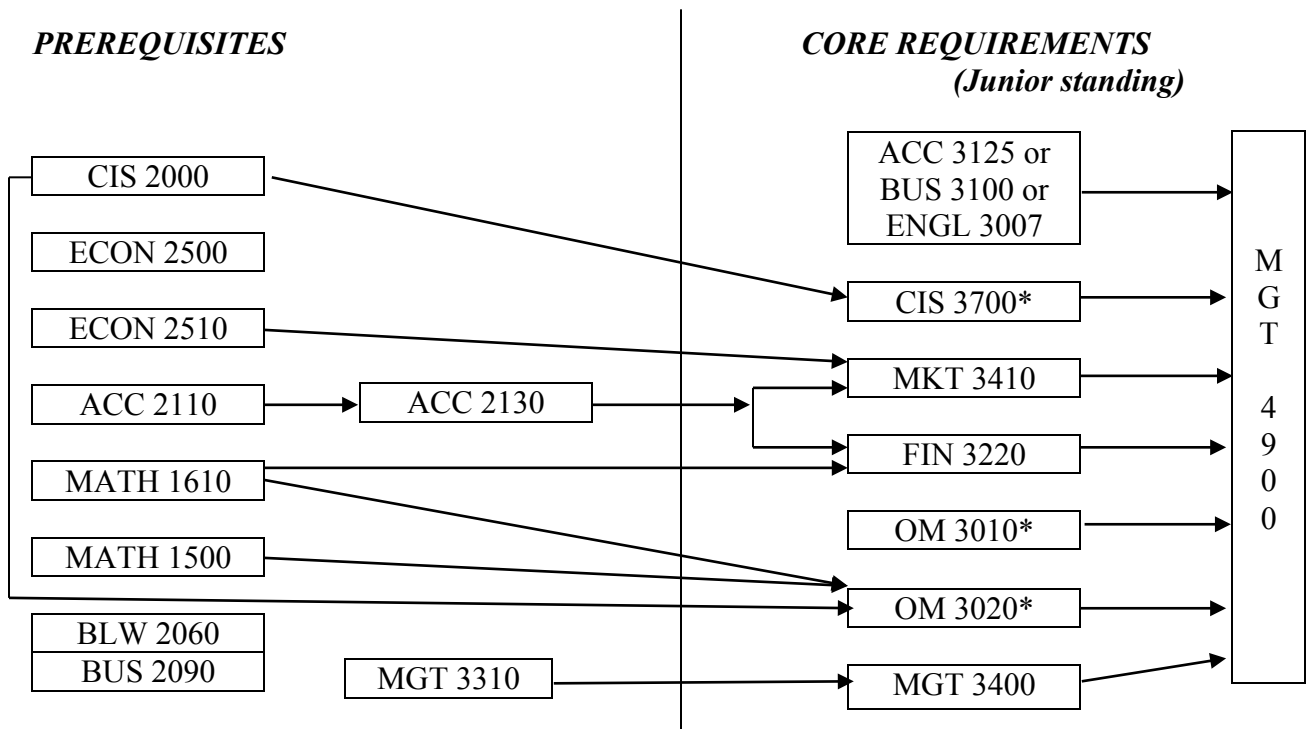

ACCOUNTING REQUIREMENTS

(Junior Standing)

