

# MARKETING CONCENTRATION

## MANAGEMENT, OPERATIONS, AND MARKETING DEPARTMENT PROGRAM EVALUATION AND PLANNING SHEET

### CATALOG YEAR 2007-2008

- NOTE: a.) This form is a companion to the CSU, Stanislaus Admission Status & General Education Evaluation Form provided by the Office of Admissions and Records - not a replacement for it. All decisions regarding admission status and General Education evaluation are made by the Office of Admissions and Records.
- b.) Be sure you have successfully completed all course prerequisites before enrolling in a course or you will not be allowed to register or stay in the course.
- c.) ALL PREREQUISITE, CORE, AND CONCENTRATION COURSES MUST BE COMPLETED WITH A GRADE OF "C-" OR BETTER.

### PREREQUISITES TO THE MAJOR

Course	Title	Term	Grade
ACC 2110	Financial Accounting		
ACC 2130	Managerial Accounting		
BLW 2060	Law, Environment, and Ethics		
ECON 2500	Principles of Macroeconomics		

Course	Title	Term	Grade
ECON 2510	Principles of Microeconomics		
MATH 1500	Finite Mathematics		
MATH 1610	Statistics for Decision Making		
BUS 3100	Business and Technical Writ <b>OR</b>		
ENGL 3007	Business Technical Comm		

### BUSINESS ADMINISTRATION CORE

Course	Title	Term	Grade
MGT 3310	Management Theory & Practice		
FIN 3220	Business Finance		
MGT 3400	International Business		
CIS 3700/3702	Information Tech. for Mgt		

Course	Title	Term	Grade
MKT 3410	Principles of Marketing		
OM 3010	Operations Management		
OM 3020/3022	Management Science		
* MGT 4900	Business Policy		

\* ALL prerequisite and business core courses must be taken before enrolling in MGT 4900, Business Policy.

### MARKETING CONCENTRATION

#### 1. Complete the following three courses (12 units):

Course	Title	Term	Grade
MKT 4400	Consumer Behavior		
MKT 4490	Strategic Marketing Management		

Course	Title	Term	Grade
MKT 4420/4422	Marketing Research		

#### 2. Complete one course from the following list of marketing courses as approved by your adviser (4 units):

Course	Title	Term	Grade
MKT 4410/4412	Advertising & Promotion Mgt.		
MKT 4430	Selling and Sales Management		
MKT 4450	Channel Inst. and Retail Mgt		

Course	Title	Term	Grade
MKT 4470/4472	Global Marketing		
MKT 4480	Product & Price Management		
MKT 4950	Special Topics in Marketing		

**Getting Started:** Before seeing your adviser, you should view the Catalog and Class Schedule online at [www.csustan.edu](http://www.csustan.edu). The list of advisors is posted on the door of DBH 223 or you can go to the Student Success Center in DBH 217/220. The catalog contains descriptions of all courses including prerequisites, core courses, and concentration courses. Lower division courses (numbered in the 1000s and 2000s) generally have acceptable equivalents transferable from a junior college. The junior college or the CSUS Academic Resource Center in MSR 180 should be able to advise you on this. Upper division courses (3000s and 4000s) must be taken at CSUS or another four-year institution.

COLLEGE OF BUSINESS ADMINISTRATION

PREREQUISITES AND CORE REQUIREMENTS

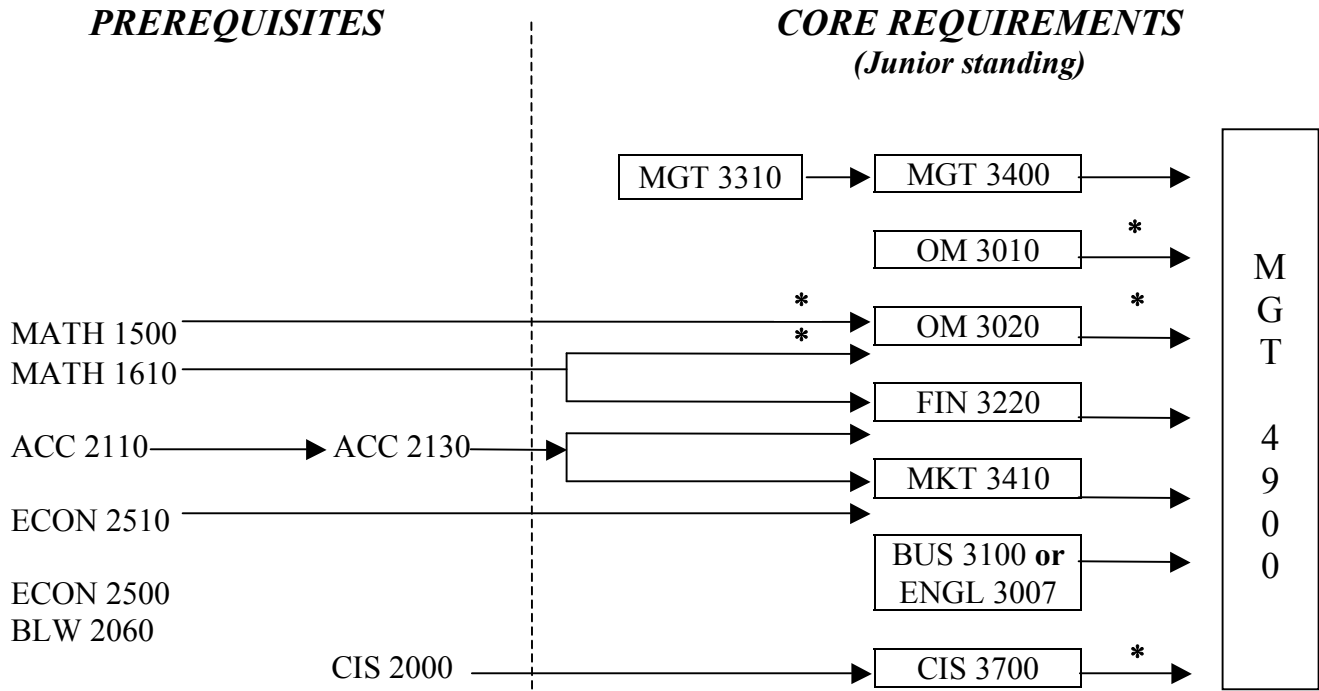

MARKETING COURSE REQUIREMENTS

