

# GENERAL BUSINESS

## MANAGEMENT, OPERATIONS, AND MARKETING DEPARTMENT PROGRAM EVALUATION AND PLANNING SHEET

### CATALOG YEAR 2007-2008

- NOTE: a) This form is a companion to the CSUS Admission Status & General Education Evaluation Form provided by the Office of Enrollment Services - not a replacement for it. All decisions regarding admission status and General Education evaluation are made by Enrollment Services.
- b) Be sure you have successfully completed all course prerequisites before enrolling in a course or you will not be allowed to register or stay in the course.
- c) ALL COURSES MUST BE COMPLETED WITH A GRADE OF "C-" OR BETTER.

### PREREQUISITES TO THE MAJOR

Course	Title	Term	Grade
ACC 2110	Financial Accounting		
ACC 2130	Management Accounting		
BLW 2060	Law, Environment and Ethics		
ECON 2500	Principles of Macroeconomics		

Course	Title	Term	Grade
ECON 2510	Principles of Microeconomics		
BUS 3100	Business & Technical Writing <b>OR</b>		
ENGL 3007	Business & Technical Comm		
MATH 1500	Finite Math		
MATH 1610	Statistics for Decision Making		

### BUSINESS ADMINISTRATION CORE

Course	Title	Term	Grade
MGT 3310	Management Theory and Practice		
FIN 3220	Business Finance		
MGT 3400	International Business		
*CIS 3700/ 3702	Information Tech. for Mgt.		

Course	Title	Term	Grade
MGT 4900	Business Policy		
MKT 3410	Principles of Marketing		
* OM 3010	Operations Management		
* OM 3020/ 3022	Management Science		

\*These courses may be taken concurrently with MGT 4900.

### GENERAL BUSINESS CONCENTRATION REQUIREMENTS

**Selected by the Student and Approved by Advisor**

(15 units of Upper Division Business Courses in at least three concentration areas in Business Administration.

These may NOT include ACC 3005, CIS 3780 or FIN 3210.)

Course	Title	Term	Grade

Course	Title	Term	Grade

**Getting Started:** Before seeing your advisor, you should view the Catalog and Class Schedule online at [www.csustan.edu](http://www.csustan.edu). The list of advisors is posted on the door of DBH 223 or you can go to the Student Success Center in DBH 217/220. The catalog contains descriptions of all courses including prerequisites, core courses, and concentration courses. Lower division courses (numbered in the 1000s and 2000s) generally have acceptable equivalents transferable from a junior college. The junior college or the CSUS Academic Resource Center in MSR 180 should be able to advise you on this. Upper division courses (3000s and 4000s) must be taken at CSUS or another four-year institution.

COLLEGE OF BUSINESS ADMINISTRATION

**PREREQUISITES AND CORE REQUIREMENTS**

*PREREQUISITES*

*CORE REQUIREMENTS*  
(Junior standing)

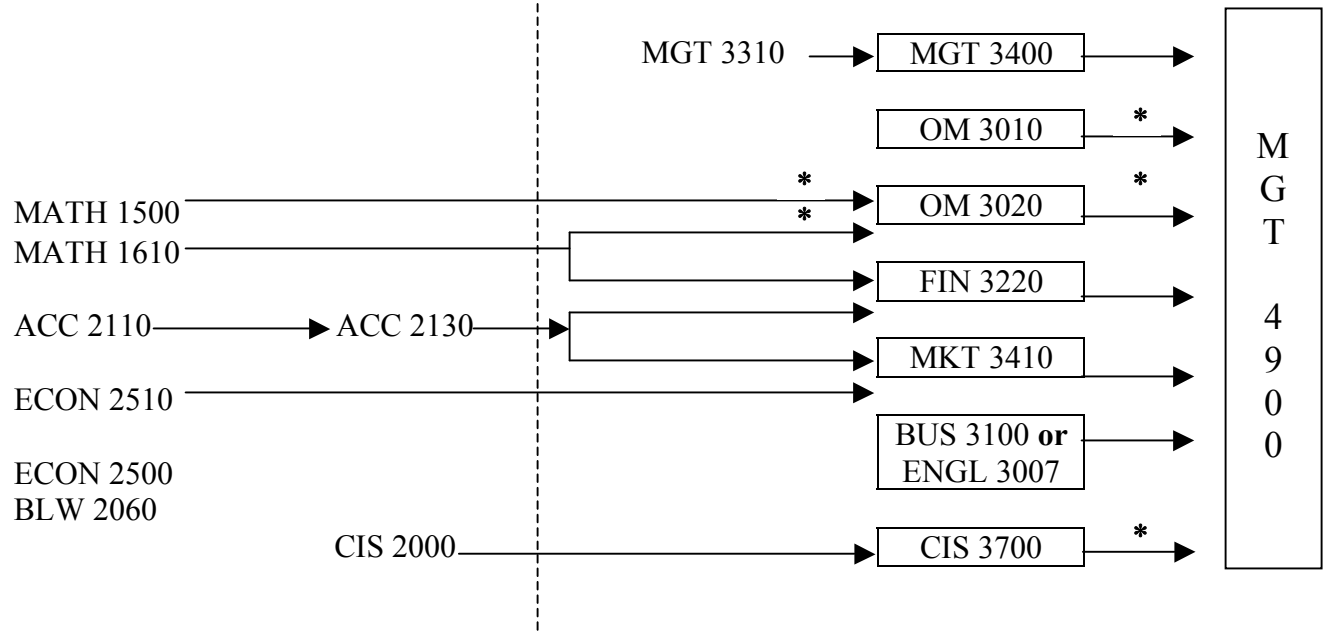

\* may be taken